



**COMMISSIONERS COURT REGULATION  
No. 12.501.072208**

**DATE APPROVED: July 22, 2008**

**EFFECTIVE DATE: July 22, 2008**

---

**ORDER FOR REGULATION OF OUTDOOR LIGHTING IN THE  
UNINCORPORATED AREAS OF BEXAR COUNTY, TEXAS  
WITHIN 3 MILES OF THE CAMP BULLIS BOUNDRIES**

*WHEREAS*, Camp Bullis is a critical training facility for the United States military, where all branches of the service train their medical personnel to function at night, under fire; and

*WHEREAS*, the continued viability of Camp Bullis for such training purposes is essential to the readiness of the United States military, the utility of Ft. Sam Houston, and the vitality of Bexar County's economy; and

*WHEREAS*, the Texas Legislature passed and Governor Rick Perry signed into law on May 25, 2007, House Bill 1852 (Corte/Van de Putte)(now Subchapter B of the Texas Local Government Code Chapter 240), providing that on the request of a United States military installation, base, or camp commanding officer, the commissioners court of a county, any part of which is located immediately adjacent to the installation, base, or camp, may adopt orders regulating the installation and use of outdoor lighting; and

*WHEREAS*, on April 9, 2008, Bexar County received a letter from Major General Russell Czerw, Commanding General, U.S. Army Medical Department Center and School and Fort Sam Houston, requesting that Bexar County issue an order regulating outdoor night-time lighting for new construction within three miles of the boundaries of Camp Bullis in order to protect military night training activities; and

*WHEREAS*, a Camp Bullis Joint Use Land Study is currently being conducted by the City of San Antonio; and

*WHEREAS*, after giving at least two weeks public notice, the Bexar County Commissioners Court conducted a hearing on the proposed adoption of this Order on July 22, 2008; and

*WHEREAS*, after conducting the public hearing, the Bexar County Commissioners Court determined to adopt the proposed Order with the intent that, upon completion of the Camp Bullis Joint Use Land Study, the Order will be reviewed for compatibility with the Study;

**NOW, THEREFORE, BE IT ORDERED BY THE COMMISSIONERS COURT OF BEXAR COUNTY, TEXAS:**

**Article I  
DEFINITIONS**

**1.1 In this Order:**

- (a) Camp Bullis: US Military training base in north Bexar County.
- (b) Camp Bullis Buffer Zone: An area the extends 3 miles in all directions from the Camp Bullis boundaries (See Exhibit 1 attached to this Order).
- (c) Direct light: Light emitted directly from the lamp, off of the reflector diffuser, or through the refractor or diffuser lens, of a luminaire.
- (d) Exempted luminaries: Luminaries that were existing, in place, and operational prior to the effective date of this light court order.
- (e) Full cutoff (FCO): Describes a luminaire light distribution where 100 candela per 1,000 lamp lumens (ten percent) may emit at all vertical angles beginning at 80 degrees up from nadir to less than 90 degrees, and zero candela per 1,000 lamp lumens (zero percent) is allowed at 90 degrees (horizontal plane) and all angles above. This applies to all horizontal angles around the luminaire. A full cutoff luminaire is also fully shielded.
- (f) Footcandle (fc): A unit of light measurement equal to one lumen per square foot.
- (g) Fully shielded: A lighting fixture constructed in such a manner that all light emitted by the fixture, either directly from the lamp or a diffusing element, or indirectly by reflection or refraction from any part of the luminaire, is projected below the horizontal plane as determined by photometric test or certified by the manufacturer. A fully shielded fixture is not necessarily full cutoff.
- (h) Glare: A luminance produced by bright sources in the field-of-view superimposed on the image in the eye reducing contrast and hence visibility.
- (i) "IESNA" (or "IES"): An acronym for the Illuminating Engineering Society of North America. The IESNA makes recommendations for outdoor lighting, but does not set outdoor lighting community standards, which are set through local court orders.

(j) Illuminance: The quantity of light arriving at a surface measured in lux or footcandles.

(k) Intermittent lighting: Luminaries that do not remain on for an extended period of time.

(l) Lumen: A unit of luminous flux. One footcandle is one lumen per square foot. For the purpose of this regulation, the lumen-output values shall be the initial lumen output ratings of a lamp. The lumen rating associated with a given lamp is generally indicated on its packaging or may be obtained from the manufacturer.

(m) Luminary: A complete lighting unit consisting of a lamp or lamps together with the parts designed to distribute the light, to position and protect the lamps and to connect the lamps to the power supply.

(n) Nadir: The direction pointing vertically down from the lowest light emitting part of the luminaire (see Exhibit 2 for an example).

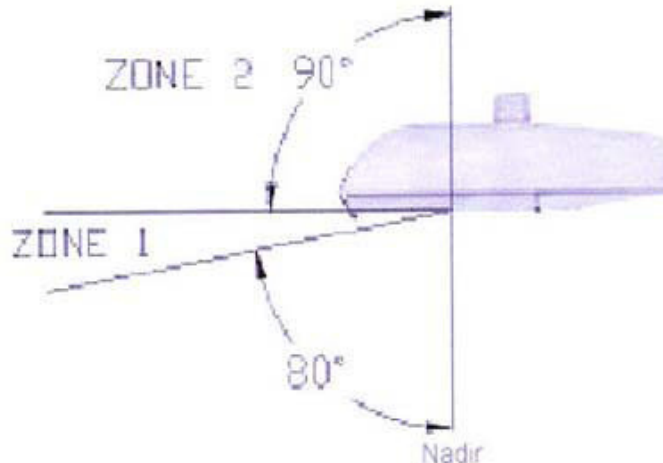

**Exhibit 2**

(o) Outdoor lighting: Nighttime illumination of an outside area or object by any man-made device that is located outdoors and produces light.

(p) Temporary outdoor lighting: Lighting for a specific unusual purpose of an outside area or object by any man-made device that produces light for a period of less than seven days, with at least 30 days passing before being used again.

(q) Trespass lighting: Light emitted by a luminary which falls outside the boundaries of the property on which the luminary is sited.

## **Article II LIGHTING REQUIREMENTS**

**2.0 Generally.** All public and private outdoor lighting installed after the effective date of this order in the Camp Bullis Buffer Zone shall be in conformance with the requirements established

by this Article.



Exhibit 3

**2.1 Control of glare.** Any luminary that is aimed, directed, or focused so as to cause direct light from the luminary to be directed toward residential buildings on adjacent or nearby land, or to create glare perceptible to persons operating motor vehicles on public ways is prohibited. Such luminary must be redirected or its light output controlled as necessary to eliminate such conditions.

**2.2 Residential lighting.**

(a) No residential trespass lighting may exceed one and one-half footcandles at the property

line, with the exception of intermittent lighting.

(b) Intermittent lighting must be of the "motion sensor" type that stays on for a period of time not to exceed five minutes and has a sensitivity setting that allows the luminary to be activated only when motion is detected on the site.

(c) It is highly recommended that all residential lighting also comply with subsections 2.3(a)(1)-(3), (a)(7) and (a)(8) below.

### **2.3 Commercial lighting.**

(a) Generally:

(1) No lighting installed on any commercial property may fit the "Unacceptable Fixture" designation as shown in Exhibit 3.

(2) For lighting horizontal tasks such as roadways, sidewalks, entrances and parking area, fixtures must meet "full cutoff" criteria (no light output emitted above 90 degrees at any lateral angle around the fixture).

(3) NEMA-head fixtures, a.k.a. "barn lights" or "dusk-to-dawn lights," shall not be permitted on any commercial property unless fitted with a county-approved reflector to render them full cutoff.

(4) "Park style" or "period style" fixtures shall not be permitted on any commercial property unless fitted with a county-approved reflector to render them full cutoff.

(5) Wallpack fixtures shall not be permitted on any commercial property unless fitted with a county-approved reflector to render them full cutoff.

(6) All trespass lighting shall not exceed two and one-half footcandles measured at the property line.

(7) Floodlight fixtures must be aimed so as to prevent direct radiation of light into the open sky at any angle above the horizontal plane as shown in Exhibit 4 and verified using the method shown in Exhibit 5.

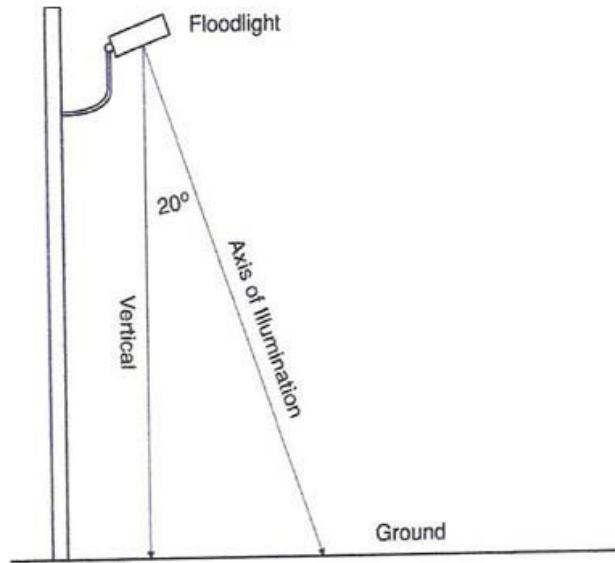

**Exhibit 4**

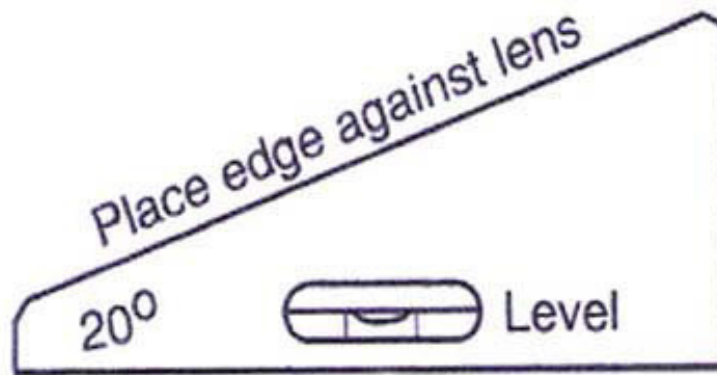

**Exhibit 5**

(8) All outdoor lighting on commercial property shall be full cutoff and the documentation to prove full cutoff status of outdoor lighting must be provided to the county from the manufacturer or firm handling the installation of said outdoor lighting.

(b) Service stations and other outdoor facilities:

(1) Outdoor sales and service stations canopies must utilize canopy lights that are fully recessed into the canopy or are fully shielded by the canopy.

(2) The following average maintained illuminance levels for service stations must not be exceeded:

Service Station Component	Lighting Level
Approach	2.0 fc

Driveway	2.0 fc
Pump Island	10.0 fc
Building Façade	3.0 fc
Service Areas	3.0 fc
Landscape Highlights	2.0 fc

**2.5 Parking lot lighting.** All parking lot lighting must be full cutoff shielding and minimum illuminance levels as defined in this Article under Exhibit 3. The recommended construction material for parking lots within the Camp Bullis Buffer Zone is bituminous concrete, better known as asphalt, to minimize reflected light from the lot surface.

**2.6 Outdoor advertising signs.**

(a) Lighting fixtures used to illuminate an outdoor advertising sign must conform to the requirements specified in this Article.

(b) Outdoor advertising signs constructed of translucent materials and wholly illuminated from within do not require shielding. Dark backgrounds with light lettering or symbols are preferred.

(c) Internally illuminated panel signs with translucent letters and symbols on an opaque background have no operational time restrictions, but should be strongly considered as unnecessary lighting. Internally illuminated panel signs with dark letters and symbols on a white background fall under the category of unnecessary lighting.

(d) Examples of necessary outdoor lighting include lighting associated with flag display, safety, and security.

(e) After closing hours, businesses must reduce outdoor lighting between the hours of 11:00 p.m. and sunrise by turning off any unnecessary lights. Any business that is open twenty-four (24) hours a day must comply with the lighting levels set out in these Regulations at all times when it is open for business.

**2.7 Local Street lighting.**

(a) Local streets are not required to have streetlights in the unincorporated area of Bexar County. However, this subsection regulates the illumination levels for streetlights that are installed on any local street.

(b) Local streetlight illumination must follow the guidelines in paragraph (d) of this subsection unless a licensed professional engineer trained and experienced in the science of illumination engineering deems other illumination levels more appropriate for existing conditions.

(c) All standard streetlights must utilize full cutoff optics (FCO) type luminaires that are installed level to the ground in two intersecting perpendicular planes (see Exhibit 6), and should be horizontally level in all directions.

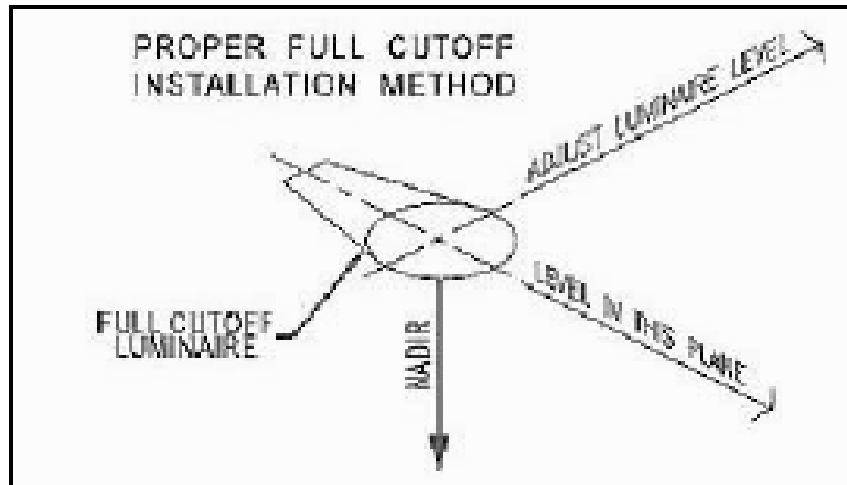

**Exhibit 6.**

(d) New ornamental street lights must be classified as either IES "Full Cutoff" or IES "Cutoff" as determined by a valid photometric report. This report must be generated for the specified model by a qualified testing lab (testing to IES standards) and must include a full vertical evaluation up through 180 degrees, otherwise that fixture will be unacceptable.

**2.8 Public Roadway Illumination.** To the extent allowed by federal and state law this Article limits luminaries used for public-roadway illumination to a maximum height of 25 feet, the location of which may be positioned at that height up to the edge of any bordering property.

**2.7 Tower and Structure Lighting.** Unless otherwise required by the Federal Communications Commission (FCC) or Federal Aviation Administration (FAA), towers or other structures requiring obstruction lighting at night must be of the minimum luminous intensity oscillating red in color.

**2.8 Other Prohibited Lighting.** Unless authorized by commissioners court by specific court order for a special event:

- (a) the use of laser source light or any similar high intensity light, such as used for outdoor advertising or entertainment, when projected above the horizontal is prohibited; and
- (b) the operation of searchlights for advertising purposes is prohibited.

### **Article III EXEMPTIONS**

3.0 The following types of outdoor lighting are exempt from the requirements of Article II:

- (a) All outdoor lighting in place prior to the effective date of this Order;
- (b) Temporary lighting as needed by police, emergency medical technicians, and fire personnel; or for meteorological data gathering purposes; and
- (c) Outdoor lighting that is owned or maintained for the purpose of illuminating:

- (1) a tract of land that is maintained as a single-family residence and that is located outside the boundaries of a platted subdivision;

- (2) a tract of land maintained for agricultural use;

- (3) an activity that takes place on a tract of land maintained for agricultural use;

- (4) structures or related improvements located on a tract of land maintained for agricultural use; or

- (5) a correctional facility operated by or under a contract with the Texas Department of Criminal Justice.

### 3.1 Usage of luminaires that do not conform with Article II.

- (a) Outdoor Recreational Facilities: No outdoor recreational facility shall be illuminated by nonconforming means from 11 PM local time to sunrise except to conclude a specific recreational activity already in progress.

- (b) Outdoor Display Lighting: Display lighting using nonconforming outdoor luminaires with metal halide bulbs must not be used for security lighting after 11 PM local time to sunrise (or after closing hours if before 11 PM local time to sunrise).

### 3.2 Maintenance and repair of luminaires that do not conform with Article II. Voluntary compliance with the following maintenance, repair, modified an/or upgrade provisions of this Order are expected of the citizens of Bexar County in an effort to enhance the military operations at Camp Bullis:

- (a) Except for lamp replacement, no luminaire should be repaired and/or modified to perpetuate its existence unless the repair and/or modification maintains conformance or makes the luminaire conforming to this Order.

- (b) If a lamp is available that makes a luminaire conform, or progress towards conformance with this Order's required illuminance level, then such a lamp should be utilized when the lamp is replaced.

- (c) Spotlights and floodlights, with a total luminous flux greater than 1800 lumens, elevated above the ground on poles or buildings and used for area lighting should be adjusted so that their

axis of illumination is at an angle not greater than 20 degrees measured from the vertical line between the fixture and the ground. This subsection applies only to spotlights and floodlights with adjustable mounts and does not apply to outdoor recreational facilities.

## **Article IV ADMINISTRATION**

### **4.0 Enforcement.**

4.1 The Department of Infrastructure Services (the “Department”) shall administer the regulations adopted in this Order.

4.2 The Department shall give written notice to the owner of the property on which a outdoor lighting violation as defined in this Order exists.

(a) The notice shall state:

(1) the specific condition that constitutes a violation; and

(2) that the person receiving notice must correct the violation not later than the 30<sup>th</sup> day after the date on which the notice is served if the person has not previously received a notice regarding a violation on the premises, or the 10<sup>th</sup> business day after the date on which the notice is served, if the person has previously received a notice of violation of this order;

(b) Failure to correct the violation after the second notice will result in a Class C Misdemeanor being filed on the owner.

(c) Written notice shall be served on the owner or his agent:

(1) In person or by registered or certified mail, return receipt requested; or

(2) If personal service cannot be obtained or the address of the owner or his agent is unknown, by posting a copy of the notice on the premises on which the nuisance exists and by publishing the notice in a newspaper with general circulation in the county two times within 10 consecutive days.

(3) If the occupier of the premises is not the owner or his agent, the occupier shall also be served with notice: (a) in person or by registered or certified mail; or (b) if personal service cannot be obtained, by posting a copy of the notice on the premises.

4.3 A separate offense occurs on each day all elements of the offense exist.

4.4 The County may not approve any further plat, permit or plan for any subdivision that installs new street lighting that does not meet the street lighting standards of this Order.

**Article V**  
**VARIANCES/ TEMPORARY EXEMPTIONS**

5.0 Variences. Commissioners Court may grant a variance to the requirements of this Order where a literal enforcement of the provisions will result in unnecessary hardship. A variance request must be submitted to the Commissioners Court in writing that sets out the basis for the request. No variance can be granted unless:

- (a) It will not be contrary to public interest;
- (b) It will be in harmony with the spirit and purposes of this Order;
- (c) The plight of the owner of the property for which the variance is sought is due to unique circumstances existing on the property, and the unique circumstances were not created by the owner of the property and are not merely financial; and
- (d) The variance will not substantially weaken the general purposes of this Order

5.2 Temporary Exemption. Any individual may submit a written request to the County Judge or designated official for a temporary exemption from the requirements of this Order. The request for the exemption must contain the following information:

- (a) Proposed use and location of the outdoor light requested.
- (b) Type of lamp or lamps to be used, including manufacturer's part number and initial lumens.
- (c) Type of light fixture used, including manufacturer's model number and specification (cut) sheets indicating photometric distribution data stated in isofotcandle diagrams.
- (e) Starting and ending dates for temporary exemption.
- (f) Contact information including name of requester, affiliation (if applicable), address and telephone number.

**Article VI**  
**VALIDITY AND SEVERABILITY**

6.1 Where any provision of federal or state law conflicts with any provision of this Order, the more restrictive provision will govern.

6.3 Severability. If any portion of this Order is held to be invalid or unconstitutional by a court of competent jurisdiction, that decree or decision shall be limited to the particular portion of this

Order determined to be invalid or unconstitutional and the remainder of the Order shall continue in full force and effect.

**Article VII  
EFFECTIVE DATE.**

This Order shall be in full force and effect from and after its date of approval.

AND APPROVED THIS DATE 2<sup>nd</sup> OF July, 2008.

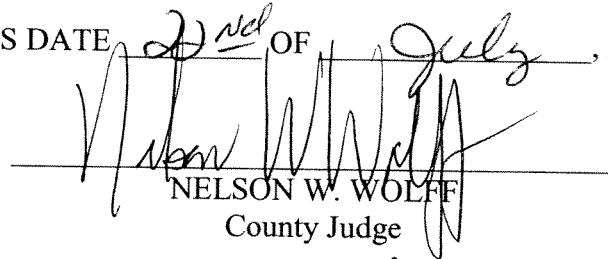
  
NELSON W. WOLFF  
County Judge

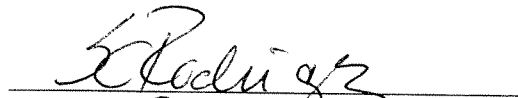
  
SERGIO "CHICO" RODRIGUEZ  
Commissioner Precinct 1

  
PAUL ELIZONDO  
Commissioner Precinct 2

  
LYLE LARSON  
Commissioner Precinct 3

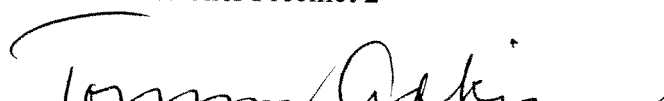
  
TOMMY ADKISSON  
Commissioner Precinct 4

# EXHIBITS:

## Exhibit 1.. Camp Bullis Buffer Zone

